

simon lighting

INSTRUCCIONES PARA LA INSTALACION, USO Y MANTENIMIENTO
INSTRUCTIONS FOR INSTALLATION, USE AND MAINTENANCE
INSTRUCTIONS POUR L'INSTALLATION, MODE D'EMPLOI ET D'ENTRETIEN

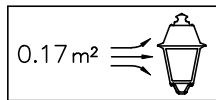

PRAGA

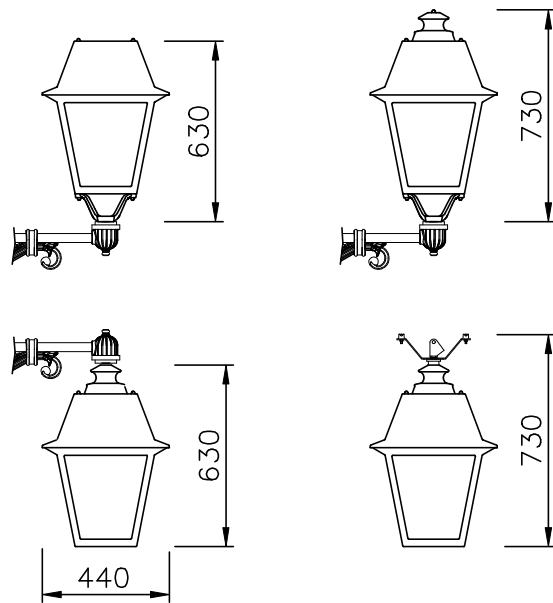
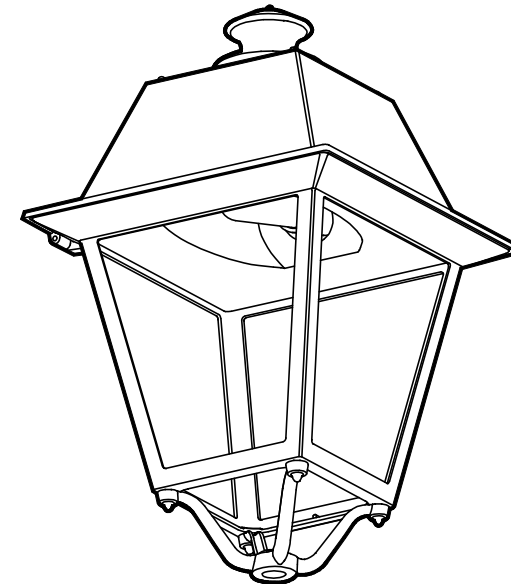

		PRAGA	LÁMPARA LAMP LAMPE	
●		50W VSAP/HPS/SHP-VMH/MH/IM (0.76A)		E-27
●	●	70W VSAP/HPS/SHP-VMH/MH/IM (1A)		E-40
●	●	70W 2N VSAP/HPS/SHP (1A)		
●	●	100W VSAP/HPS/SHP-VMH/MH/IM (1.2A)		
●	●	100W 2N VSAP/HPS/SHP (1.2A)		
●	●	150W VSAP/HPS/SHP-VMH/MH/IM (1.8A)		
●		150W 2N VSAP/HPS/SHP (1.8A)		

		PRAGA - LED	INTENSIDAD INTENSITY COURANT	ÓPTICA OPTICS OPTIQUE	TEMP. COLOR COLOUR TEMP. TEMP. COULEUR
●	●	24 LED (2M ISTANIUM) / 24 LED 2N (2M ISTANIUM)	350mA	RW	WDL: 3000K
●	●	36 LED (3M ISTANIUM) / 36 LED 2N (3M ISTANIUM)	530mA	RF	NDL: 4000K
●	●	48 LED (4M ISTANIUM) / 48 LED 2N (4M ISTANIUM)	700mA (24-36L)	RE SRF	DL: 5000K APC

IP65 IK09 LED

OBSERVACIONES	OBSERVATIONS	OBSERVATIONS
Las luminarias sin equipo no están sometidas a la directiva 93/68/CCE respecto a la compatibilidad electro-magnética. El conjunto formado por la lámpara, la luminaria y el equipo si si lo está y por tanto deben utilizarse componentes que cumplan dicha directiva. Cuando en una instalación se utilice esta luminaria con componentes de distinta fuente de suministro y no equipada en origen, la responsabilidad del cumplimiento de la directiva para este conjunto será del montador final. Esto no exime del mercado de aquellos componentes a los que la directiva afecte individualmente.	The luminaires without control gear are not regulated by the 93/68/CEE standard concerning the electromagnetic compatibility. The package including the lamp, the luminaire and the control gear is regulated by this standard and, therefore, components meeting this standard must be used. When this luminaire is used in an installation with components from different sources of supply and not equipped in origin, the responsibility of the standard's fulfilment of this package will fall on the final mounter. So it does not remit of the labeled of those components individually affected by the standard.	Les luminaires sans appareillage ne sont pas réglés par la directive 93/68/CEE concernant la compatibilité électromagnétique. L'ensemble formé par la lampe, la luminare et l'appareillage est réglé par cette directive et on doit utiliser les composants qui soient d'accord avec cette directive. Quand cette luminare est utilisé avec composants d'autres sources de fourniture et n'est pas équipée d'origine, la responsabilité de l'accomplissement de cette directive sera de l'installateur. Ceci n'exempte pas de marquer les composants affectés individuellement par la directive.

990235 (22-07-16) (v.E) 1/2



SIMON LIGHTING, S.A.
Plaza de Sant Pol de Mar 1
08030 BARCELONA
www.simonlighting.es

Atención al cliente
Tel. 902.44.77.67
Fax 902.44.77.07
tecnica@simonlighting.es

simon
CE

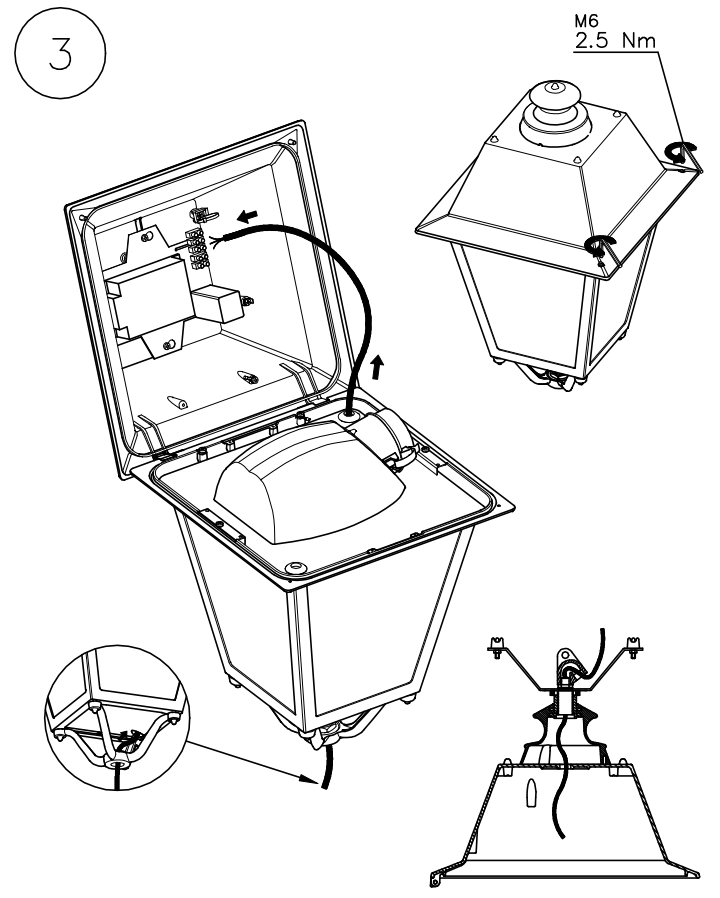
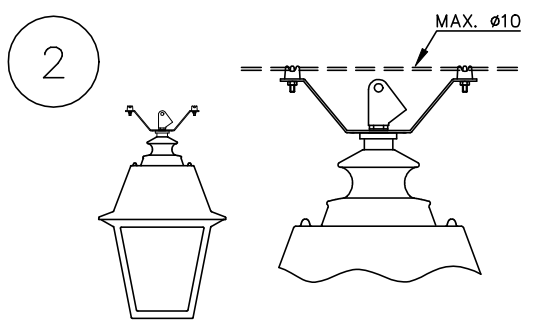
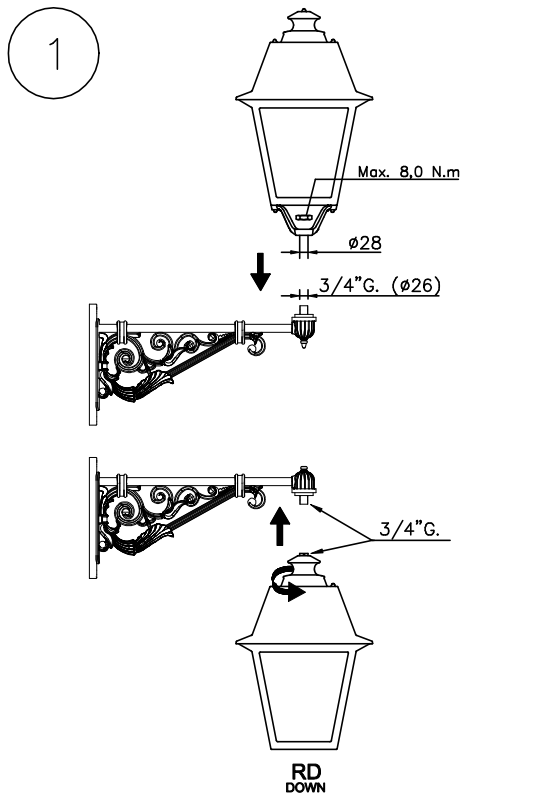

Luminaria apta montaje altura no superior a 8-10m.
This luminaire can be installed not over 8-10m. height.
Luminarie apte pour montage non superieur a 8-10m.

TIPOS DE CABLES RECOMENDADOS
RECOMMENDED CABLES / CÂBLE RECOMMANDABLE

VV-K UNE21123-1 0,6/1 KV clase 5	<p>Max. 4 mm²</p>
RV-K UNE21123-2 0,6/1 KV clase 5	

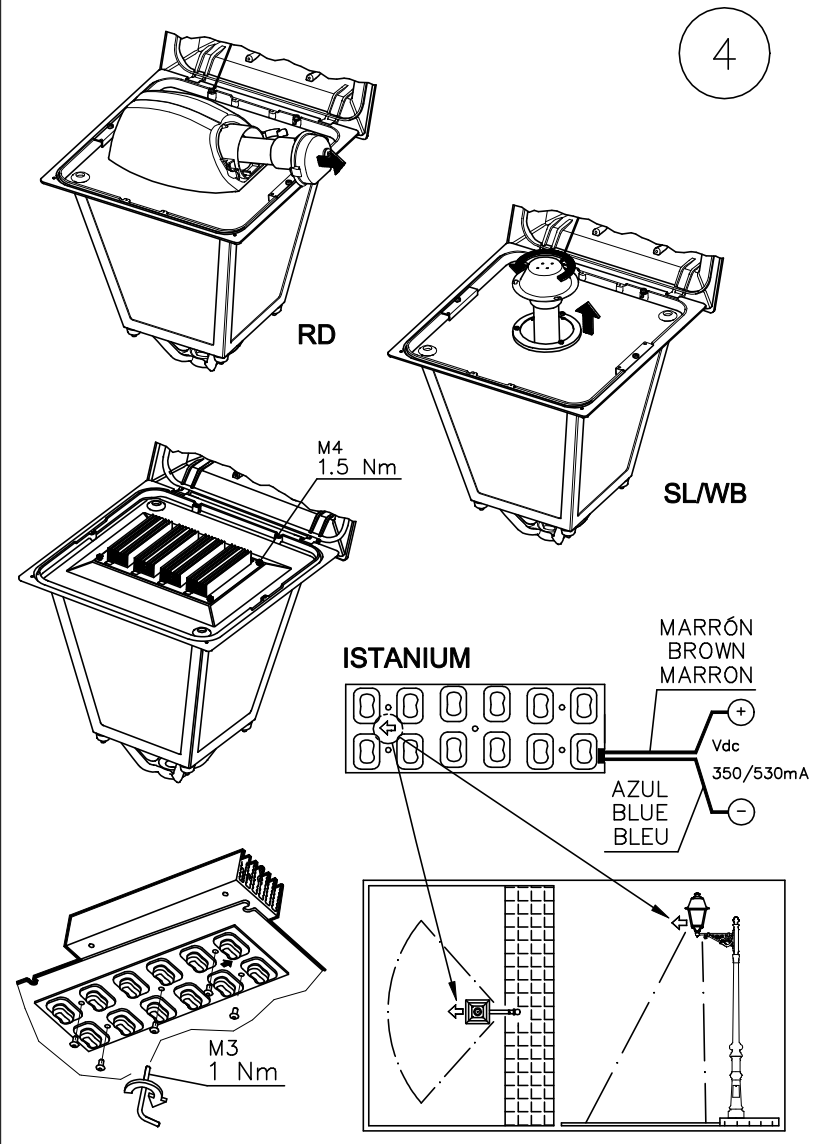

⚠ La seguridad de la luminaria está garantizada solamente con el uso apropiado de las siguientes instrucciones, por lo tanto es necesario conservarlas.
⚠ Antes de realizar las conexiones con la red eléctrica, durante el montaje o sustitución de la lámpara recuerde cortar la tensión.
⚠ Para el montaje o sustitución de la lámpara siga las instrucciones del fabricante suministradas junto con la lámpara.

⚠ The safety of the luminaire is guaranteed only by the proper use of the following instructions, so we recommend to keep them.
⚠ Before installation or lamp replacement, remember to keep off the mains voltage.
⚠ During installation or lamp replacement follow the instructions given by the manufacturer.

⚠ La sécurité de la luminaire est garantie seulement avec l'emploi convenable des instructions dont il faut les conserver.
⚠ Avant effectuer les connexions au réseau, lors du montage ou de la substitution de la lampe, s'assurer que la tension a été enlevée.
⚠ Pour la installation de ou le remplacement de la lampe, suivre les instructions fournies par le fabricant.

- ① FIJACION A COLUMNA 3/4" G.
- ② FIJACION POR CATENARIA
- ③ ACCESO AL GRUPO OPTICO Y CONEXIONADO ELECTRICO
- ④ OPCIONES DE LAMPARA

- ① POST TOP FIXING 3/4" G
- ② STRING MOUNTING
- ③ ACCESS TO THE OPTICAL UNIT AND ELECTRICAL WIRING
- ④ LAMP OPTIONS

- ① FIXATION A COLONNE 3/4" G
- ② FIXATION PAR CATÉNAIRE
- ③ ACCES AU GROUPE OPTIQUE ET CÂBLAGE ÉLECTRIC
- ④ DIFFÉRENTES OPTIONS DE LAMPES