

±	□	MIZAR	LAMPARA LAMP	Ø	REGLACIONES REGULATION
●	●	150W VSAP/APS/SPS -MM/AM/IM (0.76A)	△	—	—
●	●	170W VSAP/APS/SPS -MM/AM/IM (1A)	△	E-27	—
●	●	170W 2N VSAP/APS/SPS (1A)	△	—	H4.5
●	●	150W VSAP/APS/SPS -MM/AM/IM (1.2A)	△	—	H4.5
●	●	150W 2N VSAP/APS/SPS (1.2A)	△	—	H4.5
●	●	150W VSAP/APS/SPS -MM/AM/IM (1.8A)	△	—	H4.5
●	●	150W 2N VSAP/APS/SPS (1.8A)	△	—	H4.5
●	●	250W VSAP/APS/SPS -MM/AM/IM (3A)	△	—	H2.5
●	●	250W 2N VSAP/APS/SPS (3A)	△	—	H2.5

±	□	MIZAR - LED	WATTS WATT	OPCION OPTION	TEMP. COLOR COLOR TEMP.
●	●	24 LED (2M INSTANUM) / 24 LED 2N (2M INSTANUM)	350mA	RW	NCL: 5000K
●	●	36 LED (3M INSTANUM) / 36 LED 2N (3M INSTANUM)	530mA	RF	EL: 5000K
●	●	48 LED (4M INSTANUM) / 48 LED 2N (4M INSTANUM)	700mA	RE	APC
●	●	60 LED (5M INSTANUM) / 60 LED 2N (5M INSTANUM)	700mA	SRF	(AMBER PHOSPHOR CONVERTED)
●	●	72 LED (6M INSTANUM) / 72 LED 2N (6M INSTANUM)	(24-36L)		

IP66 IK09 LED 230V-50Hz 50/60Hz 110°

OBSERVACIONES	OBSERVATIONS	OBSERVATIONS
Los luminarias sin equipo no están sometidos a la directiva 93/68/CEE respecto a la compatibilidad electromagnética. El conjunto formado por la lámpara, la luminaria y el equipo al que está y por tanto, deben utilizarse componentes que cumplan dicha directiva. Cuando en una instalación se utiliza esta luminaria con componentes de distinta fuente de suministro y no equipado en origen, la responsabilidad del cumplimiento de la directiva para este conjunto será del montador final. Esto no exime al marcado de aquellos componentes de aquellos componentes individualmente afectados por la directiva.	The luminaires without control gear are not regulated by the 93/68/CEE standard concerning the electromagnetic compatibility. The package including the lamp, the luminaire and the control gear is regulated by this standard and, therefore, components meeting this standard must be used. When this luminaire is used in an installation with components from different sources of supply and not equipped in origin, the responsibility of the standard's fulfillment of this package will fall on the final mounter. So it does not exempt the labeling of those components affected individually by the standard.	Les luminaires sans appareillage ne sont pas réglés par la directive 93/68/CEE concernant la compatibilité électromagnétique. L'ensemble formé par la lampe, la luminare et l'appareillage qui sont réglé par cette directive et qui sont d'accord avec cette directive. Quand cette luminare est utilisé avec composants d'autres sources de fourniture et n'est pas de l'origine, la responsabilité de l'accomplissement de cette directive sera de l'installateur. Ceci n'exempte pas de marquer les composants affectés individuellement par la directive.

990256 (24-07-14) (v.D) 1/2

simon
lighting

INSTRUCCIONES PARA LA INSTALACION, USO Y MANTENIMIENTO
INSTRUCTIONS FOR INSTALLATION, USE AND MAINTENANCE
INSTRUCTIONS POUR L'INSTALLATION, MODE D'EMPLOI ET D'ENTRETIEN

MIZAR

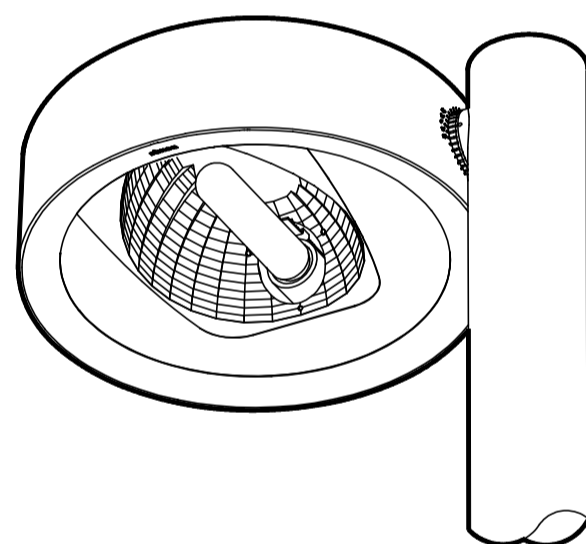

simon
CE

ABNOR
REGISTERED
SIMPLECTIC

SIMON LIGHTING, S.A.
Passe de Sant Pol de Mar 1
08030 BARCELONA
www.simonlighting.es

Atenció al client
Tel. 902.44.77.57
Fax. 902.44.77.07
tecnic@simonlighting.es

OPCIONAL - OPTIONAL - FACULTATIF

OPCION MÓDULOS LED ISTANUM
LED ISTANUM GEAR OPTION
LED ISTANUM MODULES OPTION

OPCIONAL - OPTIONAL - FACULTATIF

OPCION MÓDULOS LED ISTANUM
LED ISTANUM GEAR OPTION
LED ISTANUM MODULES OPTION

La seguridad de la luminaria está garantizada solamente con el uso apropiado de las siguientes instrucciones, por lo tanto es necesario conservarla.
Antes de realizar las conexiones con la red eléctrica, durante el montaje o sustitución de la lámpara recuerde cortar la tensión.
Para el montaje o sustitución de la lámpara siga las instrucciones del fabricante suministradas junto con la lámpara.

The safety of the luminaire is guaranteed only by the proper use of the following instructions, so we recommend to keep them.
Before installation or lamp replacement, remember to keep off the mains voltage.
During installation or lamp replacement follow the instructions given by the manufacturer.

La sécurité de la luminare est garantie seulement avec l'emploi convenable des instructions dont il faut les conserver.
Avant effectuer les connexions au réseau, lors du montage ou de la substitution de la lampe, s'assurer que la tension a été enlevée.
Pour la installation de ou le remplacement de la lampe, suivre les instructions fournies par le fabricant.

990256 (24-07-14) (v.D) 2/2