

LORE		LAMPARA LAMPE	RD	REGULACIONES REGLEMENTS
●	50W VSAP/HPS/SH/ -VMH/MH/IM (0.76A)			2
●	50W 2N VSAP/HPS/SH/ (0.76A)			2
●	70W VSAP/HPS/SH/ -VMH/MH/IM (1A)			2
●	70W 2N VSAP/HPS/SH/ (1A)			2
●	100W VSAP/HPS/SH/ -VMH/MH/IM (1.2A)			4.5
●	100W 2N VSAP/HPS/SH/ (1.2A)			4.5
●	150W VSAP/HPS/SH/ -VMH/MH/IM (1.8A)			4.5
●	150W 2N VSAP/HPS/SH/ (1.8A)			4.5
●	250W VSAP/HPS/SH/ -VMH/MH/IM (3A)			1

LORE - LED		INTERF. ENERGY COEFCIANT	OPCIÓN OPTIC	TEMP. COLOR TEMP. COULEUR
●	12 LED (IM Istanium) / 12 LED 2N (IM Istanium)			
●	24 LED (2M Istanium) / 24 LED 2N (2M Istanium)	350mA	RW	NEL: 3000K NOL: 4000K EL: 5000K
●	36 LED (3M Istanium) / 36 LED 2N (3M Istanium)	530mA	RF	
●	48 LED (4M Istanium) / 48 LED 2N (4M Istanium)	700mA	RE	APC (LAMBER PRACTICOR CONVERTED)
●	60 LED (5M Istanium) / 60 LED 2N (5M Istanium)	(24-36L)	SRF	
●	72 LED (6M Istanium) / 72 LED 2N (6M Istanium)			

IP65 IK09 LED 230V-50Hz 230V-50Hz 2W

OBSERVACIONES	OBSERVATIONS	OBSERVATIONS
Los luminarios sin equipo no están sometidos a la directiva 93/88/CEE respecto a la compatibilidad electromagnética. El conjunto formado por la lámpara, el luminario y el equipo al que se instala y por tanto deben utilizarse componentes que cumplan dicha directiva. Cuando en una instalación se utilize este luminario con componentes de distinta fuente de suministro y no equipado en origen, la responsabilidad del cumplimiento de la directiva para este conjunto será del montador final. Esto no exime del marcado de aquellos componentes o los que la directiva afecta individualmente.	The luminaires without control gear are not regulated by the 93/88/CEE standard concerning the electromagnetic compatibility. The package including the lamp, the luminaire and the control gear it is regulated by this standard and, therefore, components meeting this standard must be used. When this luminaire is used in an installation with components from different sources of supply and not equipped in origin, the responsibility of the standards fulfilment of the package will fall on the final installer. So, it does not exempt of the labelling of those components individually affected by the standard.	Les luminaires sans appareillage ne sont pas régies par la directive 93/88/CEE concernant la compatibilité électromagnétique. L'appareillage est régi par cette directive et on doit utiliser les composants qui soient d'accord avec cette directive. Quand cette luminaire est utilisé avec composants d'autres sources de fourniture et n'est pas équipé d'origine, la responsabilité de l'accomplissement de cette directive sera de l'installateur. Ceci n'exempte pas de marquer les composants affectés individuellement par la directive.

990595 (12-01-15) (v.A) 1/2

simon
lighting

INSTRUCCIONES PARA LA INSTALACION, USO Y MANTENIMIENTO
INSTRUCTIONS FOR INSTALLATION, USE AND MAINTENANCE
INSTRUCTIONS POUR L'INSTALLATION, MODE D'EMPLOI ET D'ENTRETIEN

LORE

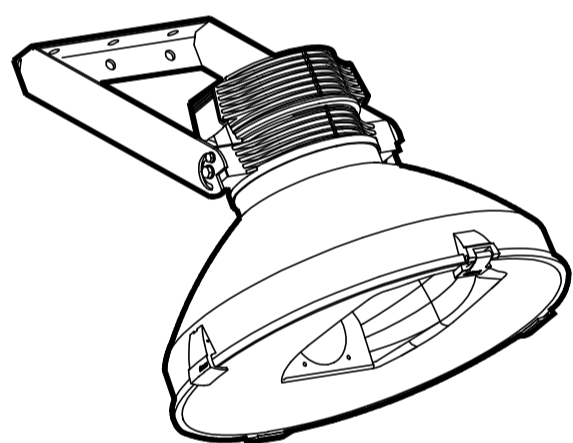

simon
CE

1 TORNEILLO DE SEGURIDAD
SAFETY SCREW
VIS DE SÛRETÉ

M6 2.5 Nm
MR 8 Nm

POSICIÓN TORNEILLO SEGURIDAD
SAFETY SCREW POSITION
POSITION VIS DE SÛRETÉ

2 JUNTA
JOINT
REFLECTOR
REFLECTEUR

M20
Max Ø12
Min. Ø7

3

4 AZUL
BLUE
M3 1 Nm
MARRÓN
BROWN

TIPOS DE CABLES RECOMENDADOS
RECOMMENDED CABLE / CÂBLES RECOMMANDÉS
VV-K UNB21123-1 0.6/1 KV class 5
VV-K UNB21123-2 0.6/1 KV class 5
7 Ø 4 mm

1 POSICIONES DE INSTALACION
2 ACCESO A LA LÁMPARA Y EQUIPO ELÉCTRICO
3 AJUSTE DEL PORTALÁMPARAS
4 OPCIÓN MÓDULOS LED Istanium

1 INSTALLATION POSITION
2 ACCESS TO THE LAMP AND ELECTRICAL GEAR
3 LAMPHOLDER ADJUSTMENT
4 LED Istanium GEAR OPTION

1 POSITIONS D'INSTALLATION
2 ACCES À LA LAMPE ET L'APPAREILLAGE
3 RÉGULATION DE LA LAMPE
4 LED Istanium MODULES OPTION

⚠ La seguridad de la luminaria está garantizada solamente con el uso apropiado de las siguientes instrucciones, por lo tanto es necesario conservarlas.
⚠ Before installation or lamp replacement, remember to keep on the same voltage.
⚠ Lors du montage ou remplacement de la lampe, suivez les instructions de fabricant fournies jointes à la lampe.

⚠ The safety of the luminaire is guaranteed only by the proper use of the following instructions, so we recommend to keep them.
⚠ Before installation or lamp replacement, remember to keep on the same voltage.
⚠ During installation or lamp replacement follow the instructions given by the manufacturer.

⚠ La sécurité de la luminarie est garantie seulement avec l'emploi convenable des instructions dont il faut les conserver.
⚠ Avant effectuer les opérations de montage ou de la substitution de la lampe, s'assurer que la tension a été maintenue.
⚠ Pour le montage ou le remplacement de la lampe, suivre les instructions fournies par le fabricant.

990595 (12-01-15) (v.A) 2/2